

HIBO LED N

Oprawa LED high bay

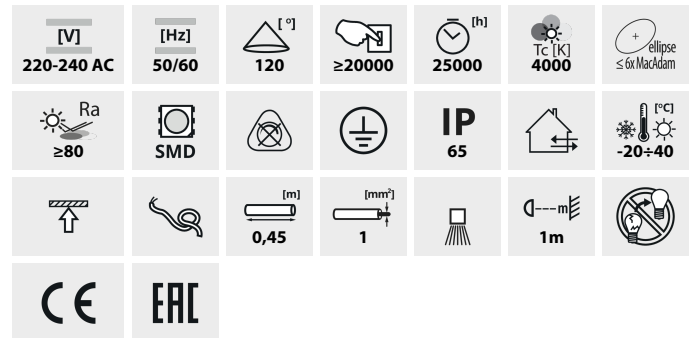

65 IP



HIBO LED N 50W-NW

			[lm]		Tc [K]	
HIBO LED N 50W-NW	31111	50	4500	4000	czarny	
HIBO LED N 100W-NW	31112	100	9000	4000	czarny	
HIBO LED N 150W-NW	31113	150	13500	4000	czarny	
HIBO LED N 200W-NW	31114	200	18000	4000	czarny	



HIBO LED to oprawa typu "High Bay" wykorzystująca moduł LED z diodami SMD. Oprawa posiada wysoki stopień szczelności IP65, dzięki czemu można ją zamontować w miejscach o wysokim zapyleniu i narażonych na działanie wody. Jest to oprawa przemysłowa, która doskonale sprawdzi się jako oświetlenie hal magazynowych, produkcyjnych oraz dużych przestrzeni handlowych.

- Materiał obudowy: stop aluminium
- Materiał szyby ochronnej: szkło

HIBO LED N

Oprawa LED high bay



HIBO LED N 50W-NW



HIBO LED N 100W-NW



HIBO LED N 150W-NW



HIBO LED N 200W-NW

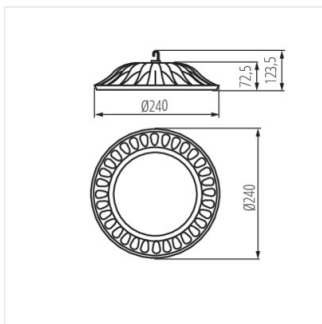

HIBO LED N 50W

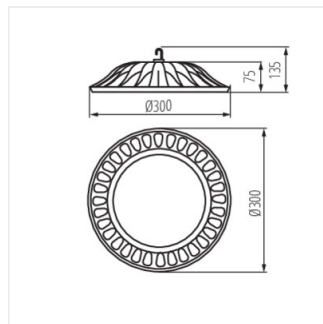

HIBO LED N 100W

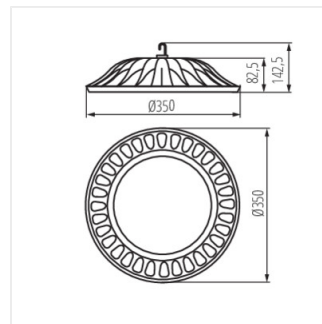

HIBO LED N 150W

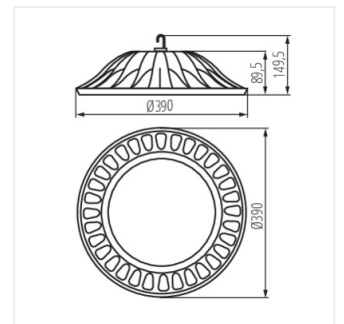

HIBO LED N 200W